

# ベンチフリューム

布設施工の能率が優れ、道路法面の排水路や農業用用水路の支線用水路などに使用します。

[形状図(ベンチフリュームI種)]

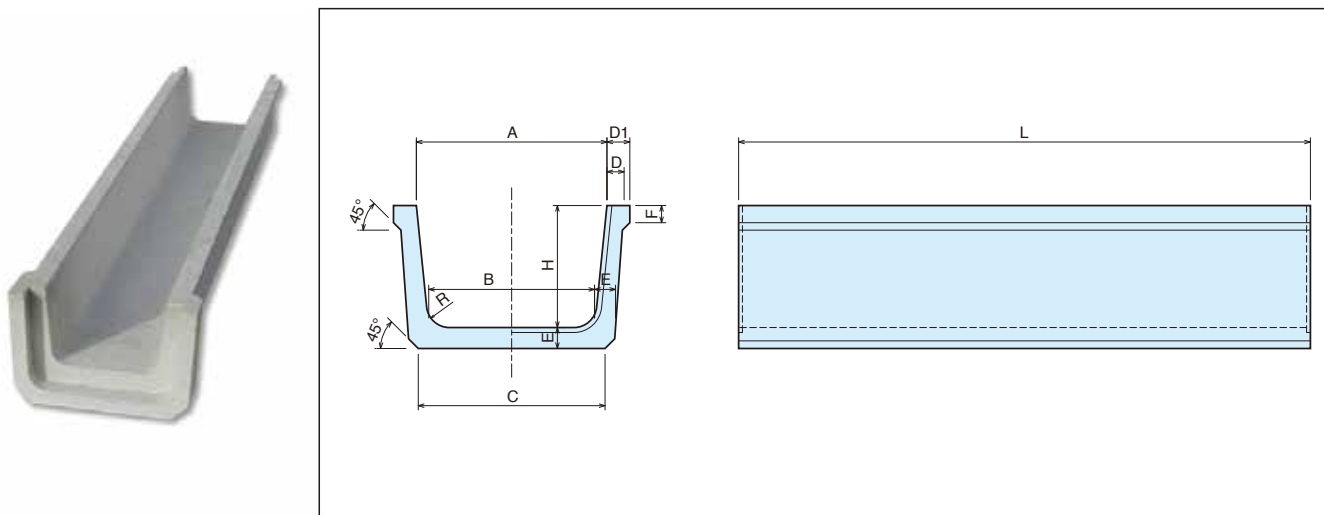

[規格表(ベンチフリュームI種)]

呼び名	形状寸法(mm)										参考質量 (Kg)
	A	B	C	D	D1	E	F	H	R	L	
200	200	170	205	30	40	35	25	150	30	2,000	87
250	250	215	250	30	40	35	30	175	30	2,000	103
300	300	260	300	30	40	40	30	200	40	2,000	133
350	350	300	345	35	45	45	35	235	50	2,000	175
400	400	345	395	40	55	50	40	260	50	2,000	222
450	450	390	440	40	55	50	40	295	50	2,000	246
500	500	435	490	45	60	55	45	320	60	2,000	301
550	550	475	535	45	-	60	-	355	60	2,000	352
600	600	520	580	45	-	60	-	380	60	2,000	378
650	650	565	630	45	-	65	-	415	70	2,000	428
700	700	610	680	50	-	70	-	440	70	2,000	494
800	800	695	770	50	-	75	-	490	70	2,000	584
900	900	785	870	55	-	85	-	550	80	2,000	742
1,000	1,000	875	965	55	-	90	-	600	80	2,000	852



[形状図(ベンチフリュームⅡ種)]

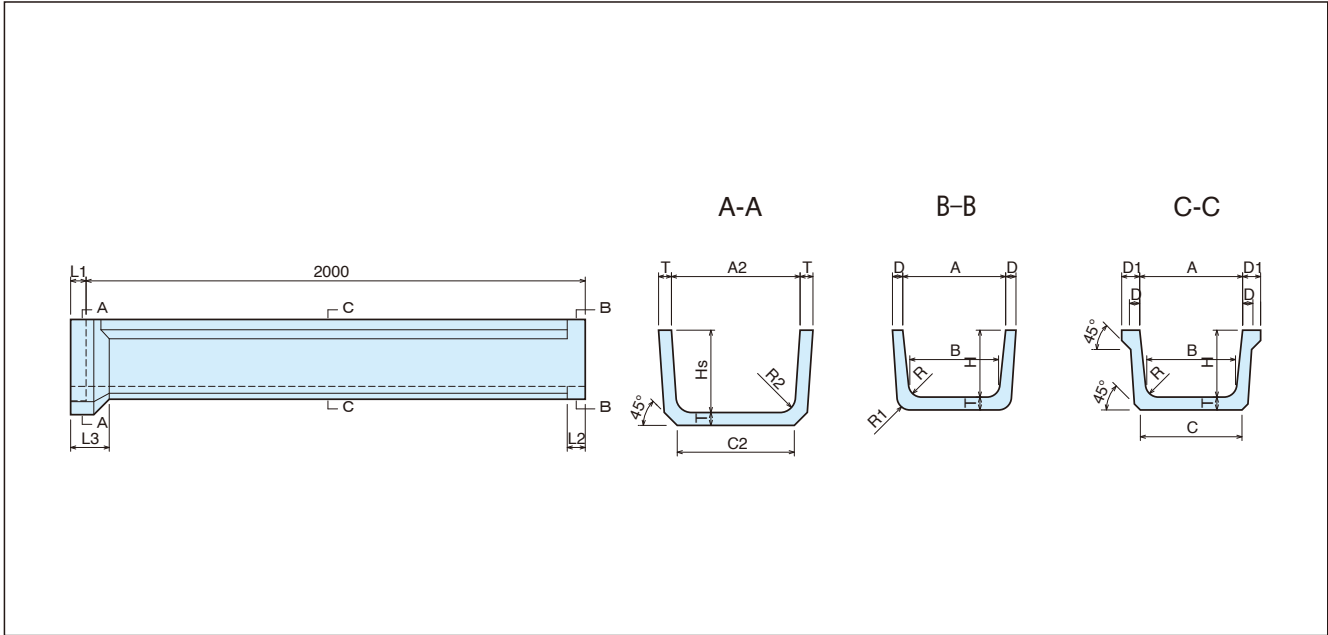

[規格表(ベンチフリュームⅡ種)]

呼び名	形状寸法 (mm)																参考質量 (Kg)
	A	B	C	H	Hs	T	D	D1	R	A2	C2	L1	L2	L3	R1	R2	
200	200	170	205	150	195	35	30	50	30	280	250	50	60	80	30	40	97
250	250	215	250	175	220	35	30	50	30	330	295	50	60	80	30	40	114
300	300	260	300	200	250	40	30	50	40	380	350	50	60	80	40	50	147
350	350	300	345	235	290	45	35	60	50	440	400	60	70	90	50	60	196
400	400	345	395	260	320	50	40	70	50	500	455	60	70	90	50	60	246
450	450	390	440	295	355	50	40	70	50	550	500	60	70	90	50	60	273
500	500	435	490	320	385	55	45	80	60	610	555	70	80	100	60	70	337
550	550	475	535	355	425	60	45	80	60	660	605	70	80	100	60	70	393
600	600	520	580	380	450	60	45	80	60	710	650	70	80	100	60	70	421
650	650	565	630	415	490	65	45	80	70	760	705	70	80	100	70	80	488
700	700	610	680	440	520	70	50	90	70	820	760	80	90	110	70	80	569
800	800	695	770	490	575	75	50	90	70	920	855	80	90	110	70	80	669
900	900	785	870	550	645	85	55	95	80	1,030	965	80	90	110	80	90	846
1,000	1,000	875	965	600	700	90	55	100	80	1,130	1,065	80	90	110	80	90	976



[通水断面図]

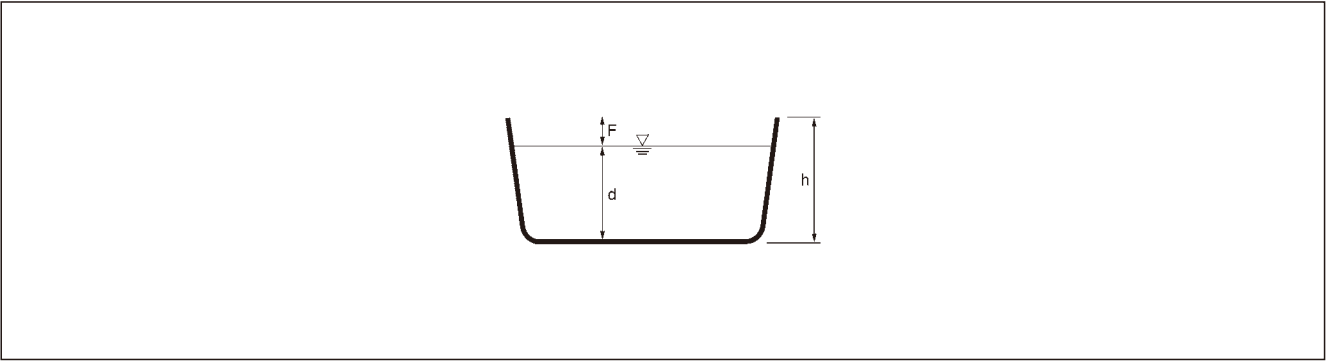

[流量表]

マンニング公式:  $V = \frac{1}{n} \cdot R^{\frac{2}{3}} \cdot I^{\frac{1}{2}}$  (m/s)、 $Q = A \cdot V$  (m<sup>3</sup>/s)  $n$  (粗度係数) = 0.014

呼び名	BF-200		BF-250		BF-300		BF-350		BF-400	
側壁高(h)mm	150		175		200		235		260	
余裕高(F)mm	50		50		50		60		60	
水深(d)mm	100		125		150		175		200	
A(m <sup>2</sup> )	0.017		0.028		0.040		0.054		0.071	
P(m)	0.351		0.446		0.534		0.619		0.714	
R(m)	0.049		0.062		0.075		0.087		0.100	
$R^{2/3}$	0.134		0.157		0.178		0.196		0.215	
勾配 $V \cdot Q$	V	Q	V	Q	V	Q	V	Q	V	Q
1/100	0.948	0.016	1.128	0.032	1.269	0.051	1.404	0.076	1.532	0.109
1/200	0.670	0.011	0.798	0.022	0.897	0.036	0.993	0.054	1.083	0.077
1/300	0.547	0.009	0.651	0.018	0.732	0.029	0.810	0.044	0.885	0.063
1/400	0.474	0.008	0.564	0.016	0.634	0.025	0.702	0.038	0.766	0.054
1/500	0.424	0.007	0.504	0.014	0.567	0.023	0.628	0.034	0.685	0.049
1/600	0.387	0.007	0.460	0.013	0.518	0.021	0.573	0.031	0.625	0.044
1/700	0.358	0.006	0.426	0.012	0.497	0.019	0.530	0.029	0.579	0.041
1/800	0.335	0.006	0.399	0.011	0.448	0.018	0.496	0.027	0.541	0.038
1/900	0.316	0.005	0.376	0.011	0.423	0.017	0.468	0.025	0.511	0.036
1/1,000	0.300	0.005	0.356	0.010	0.401	0.016	0.444	0.024	0.484	0.034
1/1,500	0.244	0.004	0.291	0.008	0.327	0.013	0.362	0.020	0.395	0.028
1/2,000	0.212	0.004	0.252	0.007	0.283	0.011	0.314	0.017	0.342	0.024



[流量表]

呼び名	BF-450		BF-500		BF-550		BF-600		BF-650	
側壁高(h)mm	295		320		355		380		415	
余裕高(F)mm	70		70		80		80		90	
水深(d)mm	225		250		275		300		325	
A(m)	0.091		0.112		0.136		0.162		0.190	
P(m)	0.809		0.897		0.988		1.083		1.171	
R(m)	0.112		0.125		0.137		0.150		0.162	
R <sup>2/3</sup>	0.232		0.250		0.266		0.282		0.297	
勾配 V・Q	V	Q	V	Q	V	Q	V	Q	V	Q
1/100	1.664	0.151	1.785	0.200	1.905	0.259	2.012	0.326	2.125	0.404
1/200	1.176	0.107	1.262	0.141	1.347	0.183	1.423	0.231	1.502	0.285
1/300	0.960	0.087	1.030	0.115	1.099	0.150	1.162	0.188	1.226	0.233
1/400	0.832	0.076	0.892	0.100	0.952	0.130	1.006	0.163	1.062	0.202
1/500	0.744	0.068	0.798	0.089	0.851	0.116	0.900	0.146	0.950	0.181
1/600	0.679	0.062	0.728	0.082	0.777	0.106	0.821	0.133	0.867	0.165
1/700	0.629	0.057	0.674	0.076	0.720	0.098	0.760	0.123	0.803	0.153
1/800	0.588	0.054	0.631	0.071	0.673	0.092	0.711	0.115	0.751	0.143
1/900	0.554	0.050	0.595	0.067	0.635	0.086	0.671	0.109	0.708	0.135
1/1,000	0.526	0.048	0.564	0.063	0.602	0.082	0.636	0.103	0.672	0.128
1/1,500	0.429	0.039	0.460	0.052	0.491	0.067	0.519	0.084	0.548	0.104
1/2,000	0.372	0.034	0.399	0.045	0.426	0.058	0.450	0.073	0.475	0.090

呼び名	BF-700		BF-800		BF-900		BF-1,000	
側壁高(h)mm	440		490		550		600	
余裕高(F)mm	90		90		100		100	
水深(d)mm	350		400		450		500	
A(m)	0.222		0.291		0.369		0.458	
P(m)	1.267		1.453		1.636		1.827	
R(m)	0.175		0.200		0.225		0.251	
R <sup>2/3</sup>	0.313		0.342		0.370		0.398	
勾配 V・Q	V	Q	V	Q	V	Q	V	Q
1/100	2.236	0.496	2.445	0.711	2.647	0.977	2.840	1.301
1/200	1.581	0.351	1.728	0.503	1.871	0.691	2.008	0.920
1/300	1.291	0.287	1.411	0.411	1.528	0.564	1.639	0.751
1/400	1.118	0.248	1.222	0.356	1.323	0.488	1.420	0.650
1/500	1.000	0.222	1.093	0.318	1.183	0.437	1.270	0.582
1/600	0.913	0.203	0.998	0.290	1.080	0.399	1.159	0.531
1/700	0.845	0.188	0.924	0.269	1.000	0.369	1.073	0.492
1/800	0.790	0.176	0.864	0.252	0.935	0.345	1.004	0.460
1/900	0.745	0.166	0.815	0.237	0.882	0.326	0.946	0.434
1/1,000	0.707	0.157	0.773	0.225	0.837	0.309	0.898	0.411
1/1,500	0.577	0.128	0.631	0.184	0.683	0.252	0.733	0.336
1/2,000	0.500	0.111	0.546	0.159	0.591	0.218	0.635	0.291